

High Productivity Cooking Electric Rectangular Boiling Pan, 80lt Hygienic Profile, Freestanding + Tap

ITEM # _____

MODEL # _____

NAME # _____

SIS # _____

AIA # _____

586517 (PBEN08ECEM)

 Electric Boiling Pan 80lt (h),
 rectangular with mixing tap,
 GuideYou panel,
 freestanding

Short Form Specification

Item No. _____

AISI 304 stainless steel construction. Vessel with rounded edges in AISI 316 stainless steel. Insulated and counterbalanced lid. Water mixing unit included. Unit to include food tap. Food is uniformly heated via the base and the side walls of the pan by an indirect heating system using integrally generated saturated steam at a maximum temperature of 125°C in a jacket with an automatic deaeration system. Safety valve avoids overpressure of the steam in the jacket. Safety thermostat protects against low water level in the double jacket. TOUCH control panel. SOFT function. Possibility to store recipes in single or multiphase cooking process, with different temperature settings. Built in temperature sensors for precise control of cooking process. IPX6 water resistant. Configuration: Free-standing or Standing against a wall. Installation options (not included): floor mounted on 200mm high feet or a plinth which can be either steel or masonry construction.

Main Features

- Kettle is suitable to boil, steam, poach, braise or simmer all kinds of produce.
- Square inner kettle allows working with stacked Gastronorm containers, which facilitate loading and unloading operations.
- Large capacity food tap enables safe and effortless discharging of contents.
- Isolated upper well rim avoids risk of harm for the user.
- Discharge tap is very easy to disassemble and clean.
- IPX6 water resistant.
- Built in temperature sensor to precisely control the cooking process.
- USB connection to easily update the software, upload/download recipes and download HACCP data.
- Connectivity ready for real time access to connected appliances from remote and data monitoring (requires optional accessory - contact the Company for more details).

Construction

- Cooking vessel in 1.4435 (AISI 316L) stainless steel. Double-jacket in 1.4404 (AISI 316L) stainless steel designed to operate at a pressure of 1.5 bar.
- External panelling and internal frame made of 1.4301 (AISI 304) stainless steel.
- Safety valve avoids overpressure of the steam in the double jacket.
- 2" diameter discharge tap for rapid emptying of the well.
- Minimised presence of narrow gaps for easier cleaning of the sides to meet the highest hygiene standards.
- Integrated water mixing tap to make water filling and pan cleaning operations easier.
- Can be prearranged for energy optimisation or external surveillance systems (optional).
- GuideYou Panel - activated by the user via settings - to easily follow the multiphase recipes, granting a proper and controlled cooking and a better appliance optimization. The system will provide maintenance reminders, in line with ESSENTIA program, helping the user to properly take care of the product, avoiding downtimes.
- Highly-visible and bright led TOUCH control panel features user-friendly icons and intuitive self-explanatory command options. Display visualizes:
 - Actual and set temperature
 - Set and remaining cooking time
 - Pre-heating phase (if activated)

APPROVAL: _____

- GuideYou Panel (if activated)
- Deferred start
 - Soft Function to reach the target temperature smoothly
- 9 Power Control levels from simmering to fierce boiling
- Pressure mode (in pressure models)
- Stirrer ON/OFF settings (in round boiling models)
- Error codes for quick trouble-shooting
- Maintenance reminders

Sustainability



- High-quality thermal insulation of the pan saves energy and keeps operating ambient temperature low.

Optional Accessories

- | | |
|--|--|
| <ul style="list-style-type: none"> • Strainer for dumplings for all tilting & stationary braising and pressure braising pans (except 80lt) and for all stationary rectangular and 100lt round boiling pans PNC 910053 <input type="checkbox"/> • Scraper for dumpling strainer for boiling and braising pans PNC 910058 <input type="checkbox"/> • Base plate for 80lt rectangular boiling pans PNC 910181 <input type="checkbox"/> • Suspension frame GN1/1 for rectangular boiling and braising pans PNC 910191 <input type="checkbox"/> • Manometer kit for stationary boiling pans - long - factory fitted PNC 912120 <input type="checkbox"/> • Power Socket, CEE16, built-in, 16A/400V, IP67, red-white - factory fitted PNC 912468 <input type="checkbox"/> • Power Socket, CEE32, built-in, 32A/400V, IP67, red-white - factory fitted PNC 912469 <input type="checkbox"/> • Power Socket, SCHUKO, built-in, 16A/230V, IP68, blue-white - factory fitted PNC 912470 <input type="checkbox"/> • Power Socket, TYP23, built-in, 16A/230V, IP55, black - factory fitted PNC 912471 <input type="checkbox"/> • Power Socket, TYP25, built-in, 16A/400V, IP55, black - factory fitted PNC 912472 <input type="checkbox"/> • Power Socket, SCHUKO, built-in, 16A/230V, IP55, black - factory fitted PNC 912473 <input type="checkbox"/> • Power Socket, CEE16, built-in, 16A/230V, IP67, blue-white - factory fitted PNC 912474 <input type="checkbox"/> • Power Socket, TYP23, built-in, 16A/230V, IP54, blue - factory fitted PNC 912475 <input type="checkbox"/> • Power Socket, SCHUKO, built-in, 16A/230V, IP54, blue - factory fitted PNC 912476 <input type="checkbox"/> • Power Socket, TYP25, built-in, 16A/400V, IP54, red-white - factory fitted PNC 912477 <input type="checkbox"/> • Measuring rod and strainer for 80lt stationary rectangular boiling pans PNC 912480 <input type="checkbox"/> • Connecting rail kit, 900mm PNC 912502 <input type="checkbox"/> • Stainless steel plinth for stationary units - freestanding - factory fitted PNC 912717 <input type="checkbox"/> • Set of 4 feet for stationary units (height 200mm) - factory fitted PNC 912732 <input type="checkbox"/> • Automatic water filling (hot and cold) for stationary units (width 700-1000mm): rectangular pressure boiling and braising pans - factory fitted PNC 912736 <input type="checkbox"/> • Kit energy optimization and potential free contact - factory fitted PNC 912737 <input type="checkbox"/> • Mainswitch 60A, 6mm² - factory fitted PNC 912740 <input type="checkbox"/> | <ul style="list-style-type: none"> • External touch control device for stationary units - factory fitted PNC 912783 <input type="checkbox"/> • Connecting rail kit: modular 90 (on the left) to ProThermetic tilting (on the right), ProThermetic stationary (on the left) to ProThermetic tilting (on the right) PNC 912975 <input type="checkbox"/> • Connecting rail kit: modular 80 (on the right) to ProThermetic tilting (on the left), ProThermetic stationary (on the right) to ProThermetic tilting (on the left) PNC 912976 <input type="checkbox"/> • Kit endrail and side panels, flush-fitting, left - factory fitted PNC 913394 <input type="checkbox"/> • Kit endrail and side panels, flush-fitting, right - factory fitted PNC 913395 <input type="checkbox"/> • Kit endrail and side panel (12.5mm), for installation thermaline 90 modular 700 mm high with ProThermetic stationary, left - factory fitted PNC 913418 <input type="checkbox"/> • Kit endrail and side panel (12.5mm), for installation thermaline 90 modular 700 mm high with ProThermetic stationary, right - factory fitted PNC 913419 <input type="checkbox"/> • Drain standpipe for boiling pans (PBEN08) PNC 913428 <input type="checkbox"/> • Kit endrail and side panels, flush-fitting, for back-to-back installation, left - factory fitted PNC 913483 <input type="checkbox"/> • Kit endrail and side panels, flush-fitting, for back-to-back installation, right - factory fitted PNC 913484 <input type="checkbox"/> • Kit endrail and side panel (12.5mm), for back-to-back installation, left - factory fitted PNC 913495 <input type="checkbox"/> • Kit endrail and side panel (12.5mm), for back-to-back installation, right - factory fitted PNC 913496 <input type="checkbox"/> • Connectivity kit for ProThermetic Boiling and Braising Pans ECAP - factory fitted PNC 913577 <input type="checkbox"/> |
|--|--|

Front

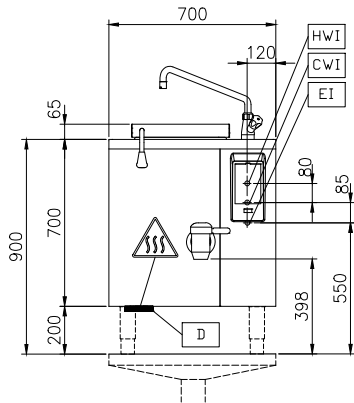

Side

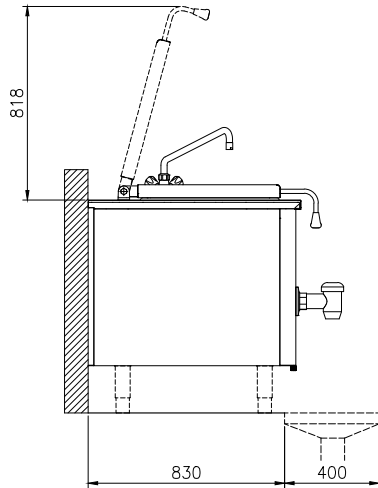

CWI = Cold Water inlet 1 (cleaning)
EI = Electrical inlet (power)
HWI = Hot water inlet

Top

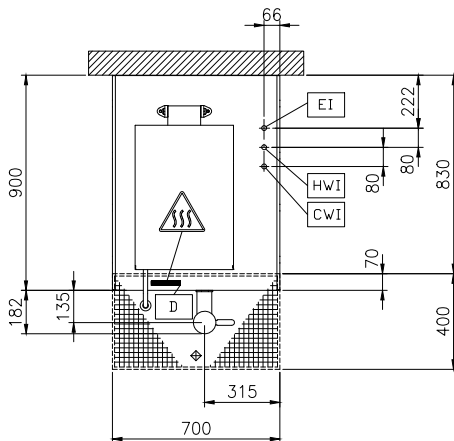

Electric

Supply voltage:

586517 (PBEN08ECEM) 400 V/3N ph/50/60 Hz

Total Watts:

18.2 kW

Installation:

Type of installation:

FS on concrete base; FS on feet; On base; Standing against wall

Key Information:

Configuration:

Rectangular; Fixed; FreeStanding

Working Temperature MIN:

50 °C

Working Temperature MAX:

110 °C

Vessel (rectangle) width:

356 mm

Vessel (rectangle) height:

461 mm

Vessel (rectangle) depth:

556 mm

External dimensions, Width:

700 mm

External dimensions, Depth:

900 mm

External dimensions, Height:

700 mm

Net weight:

150 kg

Net vessel useful capacity:

80 lt

Double jacketed lid:

✓

Heating type:

Indirect